

**Complete and Customizable Communications Solutions**

# ADECIA

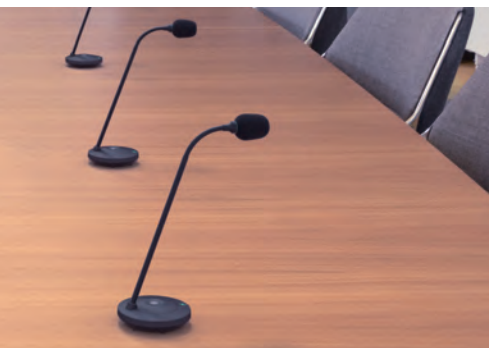
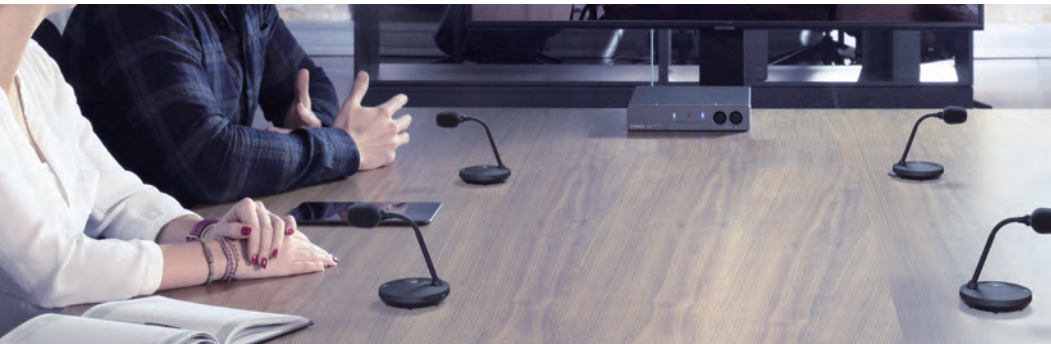

# “SOUND” ACCELERATES BUSINESS.

With new and ever-changing communication requirements, one thing remains the same: the need for high-quality, worry-free audio for collaboration. ADECIA helps organizations overcome challenges with implementation, configuration and room acoustics by providing all components required for a successful installation - designed to work seamlessly together to reduce set up time, costs and complexities.

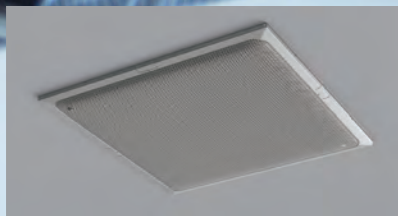

Ceiling Array  
Microphone  
**RM-CG**

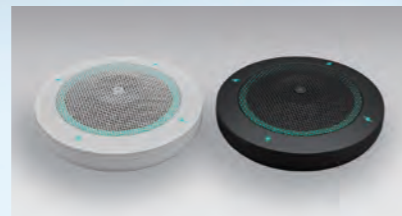

Tabletop Array  
Microphone  
**RM-TT**



Wireless Microphone  
System  
**RM-W**



Remote Conference  
Processor  
**RM-CR**



## Complete Coverage from Sound Input to Output

ADECIA helps organizations overcome challenges with implementation, configuration and room acoustics by providing all components required for a successful installation - designed to work seamlessly together to reduce set up time, costs and complexities.

## Reduce Time, Spend and Complexities

Audio/control signals can be transmitted with one network cable using the audio network standard, "Dante", solving troublesome wiring and installation problems.

## Natural and Comfortable Conversation Experiences

Each microphone is equipped with various processing functions and when combined with Yamaha's original voice processing technology "HVAD" (Human Voice Activity Detection), it provides a smooth and stress-free remote conferencing experience. HVAD is Yamaha's technology to distinguish human voice from background noises. HVAD captures human voices and suppresses background noises, delivering a clear signal to the far end no matter where you meet.

## Best Audio in Shortest Time

ADECIA automatically detects all components and configures them to be optimized for the room environment, taking into consideration location of speakers and microphones, reverberation characteristics of the room, and echo behavior. Setting up a room can be as easy as following the configurator through four steps of configuration.

## Customization Options to Fit Your Use Case

By offering a wide range of variations such as ceiling array microphones, tabletop array microphones, and wireless microphone systems, ADECIA meets the demands of different audio solutions for each conference, meeting or learning space and provides operations suitable for various environments.

## Integration into All Audio Environments

Equipped with various interfaces such as USB, Bluetooth®, SIP, and analog audio input/output terminals, the system allows the flexibility to use both web conference systems and telephone line conferences. Supporting Windows, macOS, iOS and Android, as well as compliance with market leading UC applications, ADECIA gives you the flexibility to customize the solution to your specific needs.

## System Examples

### RM-CG System Example

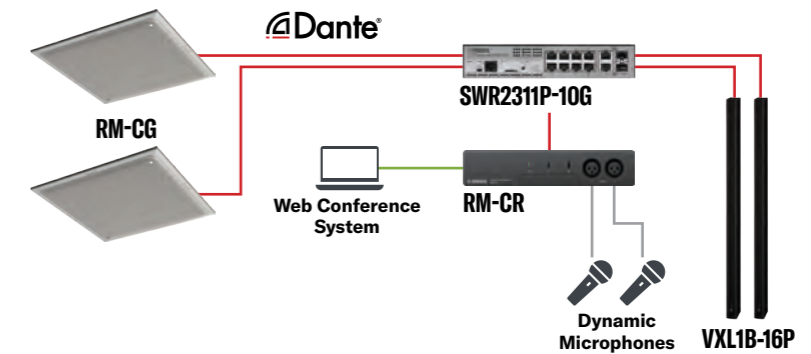

### RM-TT System Example

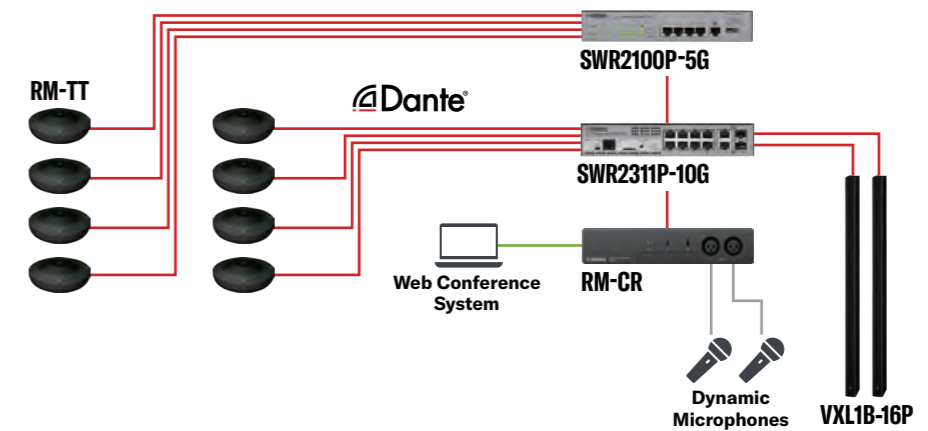

### RM-W System Example

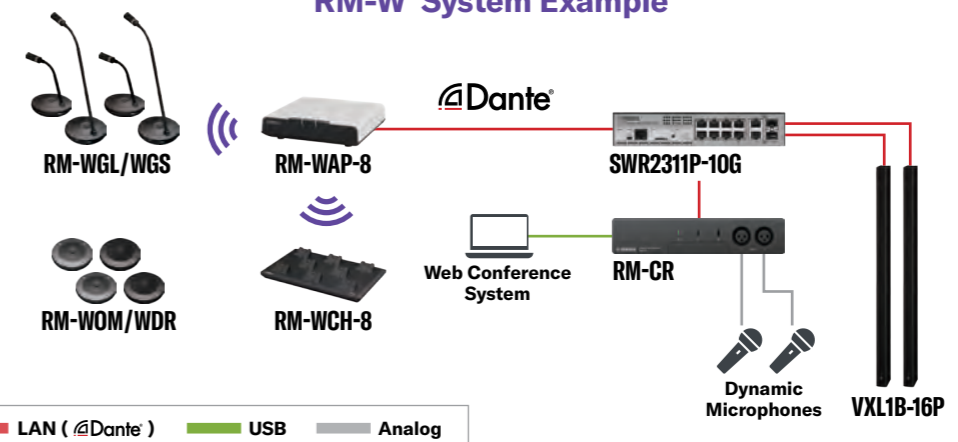

— LAN (@Dante) — USB — Analog

# Sound Processing for High Quality Remote Conferencing Experience

## Multi-beam Tracking (RM-CG)

Multi-beam Tracking is a signal processing technology that can track multiple speaking participants by combining the use of beamforming technology to form directivity with multiple microphone elements to pick up sound. With multiple beams, each beam tracks different speakers' voices when multiple speakers are present.



## Auto Voice Tracking (RM-TT)

The RM-TT is equipped with Auto Voice Tracking (automatic speaker tracking function) in each microphone, allowing for flexible room layout and participant positioning. RM-CR automatically selects the closest microphone to the speaker to pick up sound, enabling a highly clear voice to the far end.



## High-speed Echo Canceller (RM-W)

Moving microphone itself or moving things near it usually causes echoes in typical microphone system, resulting in interruptions and stress. As the RM-W is equipped with an excellent high-speed echo canceller that can instantly remove the echoes, you can experience a stress-free focused conversation.



## Unique Yamaha Processing Technologies

Yamaha's unique HVAD technology distinguishes the human voice vs. noise to block unneeded sound from being sent to the far-end.

### 1 ADAPTIVE ECHO CANCELLER

While other echo cancellers measure the room and set levels once, Yamaha's adaptive echo cancellation is constantly scanning the environment for changes to deliver an uninterrupted, echo-free audio stream.

### 2 AUTO GAIN CONTROL

This sound technology automatically adjusts voice levels to deliver a consistent, optimal volume level to the far-end, no matter if some voices are louder vs. weaker or closer vs. further away from the microphone. This automatic feature enables everyone to hear or be heard at an ideal level.

### 3 NOISE REDUCTION

When constant noise like a projector fan or air conditioner system enters the communication space, Yamaha's Noise Reduction technology removes these components to clearly convey the presenter's audio to the far-end.

### 4 DEREVERBERATION

Reverberation from an acoustically-poor environment can make it difficult to distinguish a clear voice signal. Dereverberation suppresses these reverb components to deliver a highly-intelligible output.

# Various Mounting Methods to Best Fit Your Usage

## Ceiling Array Microphone RM-CG Installation

Ceiling Mount

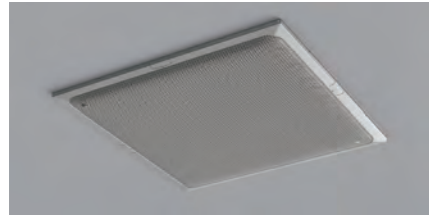

Wire Mount

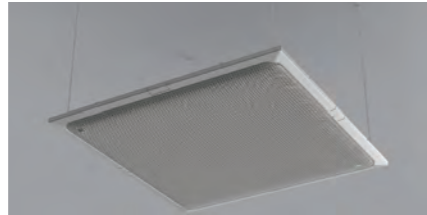

VESA Mount

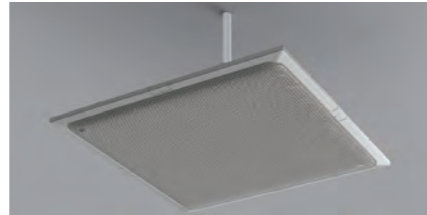

## Tabletop Array Microphone RM-TT Mount

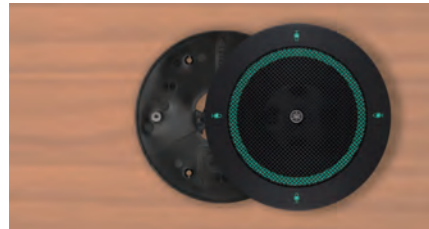

## Wireless Access Point RM-WAP-8 Installation



## Remote Conference Processor RM-CR Installation

Rack Mount



Table Mount



# Setup Wizard

## Quick Setup (RM-CR)

Follow the setup wizard on your web browser and with just a few clicks it will automatically adjust the audio according to your system's audio routing and room environment.

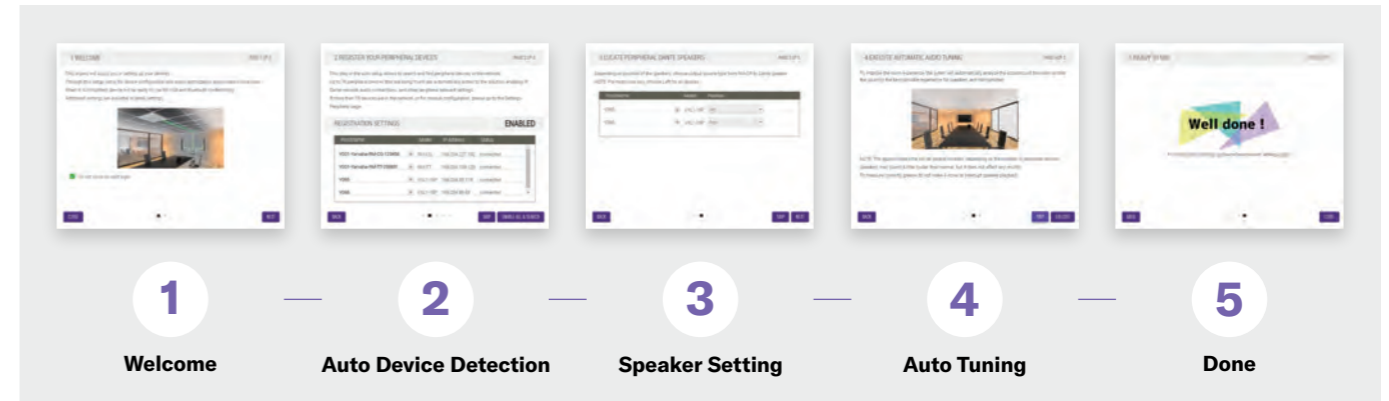

## Pairing (RM-W Series)

Each microphone can be easily paired from the Web UI. You can pair the microphone individually, or pair multiple microphones on the microphone charging station at once.

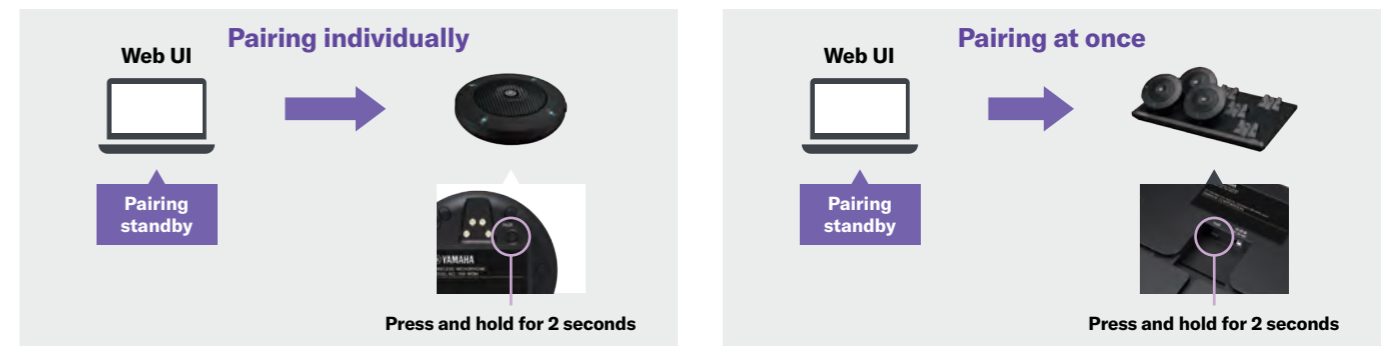

## Monitoring (RM-WAP-8)

You can monitor radio wave conditions with the Web UI.

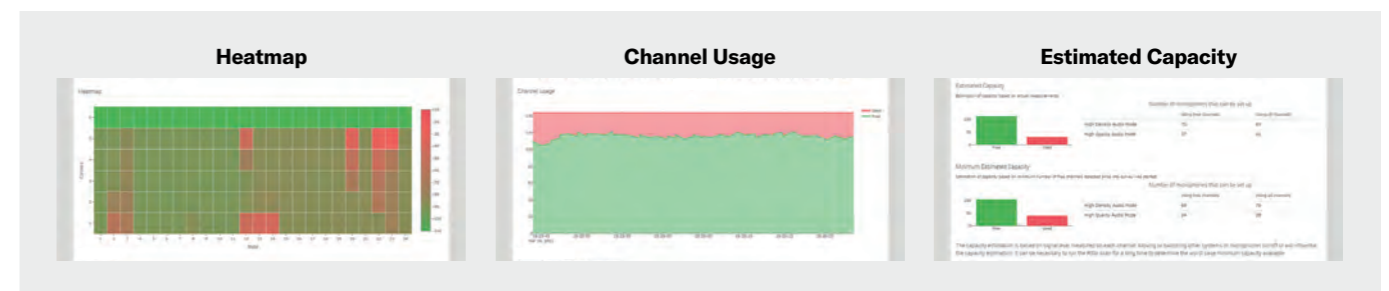

# Flexible Application Support

## Ceiling Solution

With a simple and sophisticated design, the unit blends into high-end spaces and enables a clean and clear table.

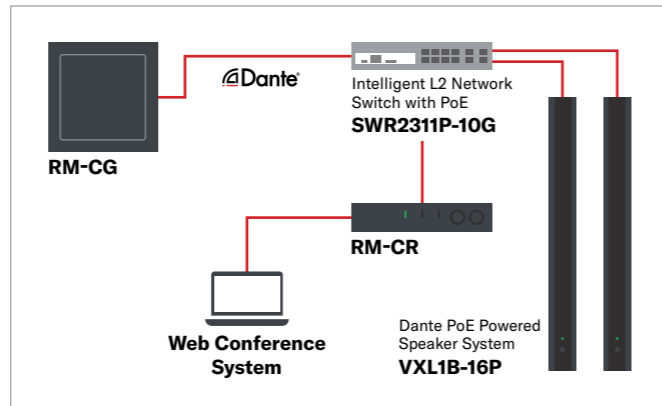
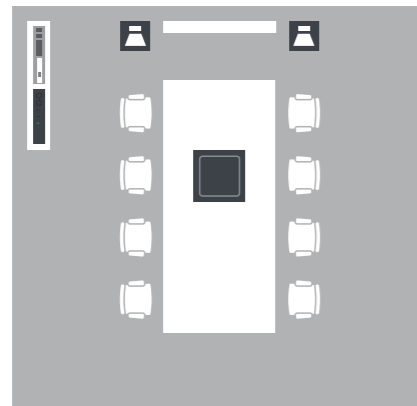

## Wireless Solution

Flexibility to choose between gooseneck and boundary microphones to adapt to your use-case, creating the most comfortable conferencing space without worrying about wiring or configuration changes should the layout change.

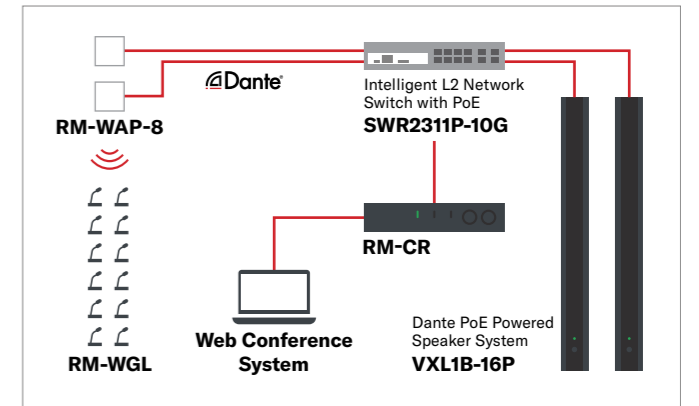
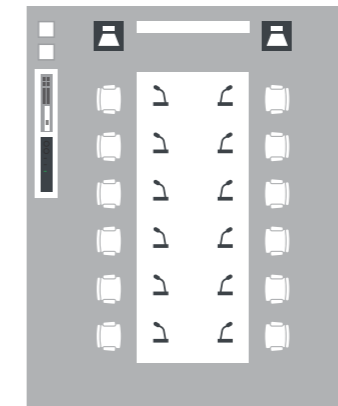

## Tabletop Solution

Scale and expand your coverage with the ability to increase the number of microphones used to fit your participant count. Up to 14 (\*) microphone pods (4 mics per pod) simply connect to the PoE switch.

\* Without VXL1-16P, up to 16.

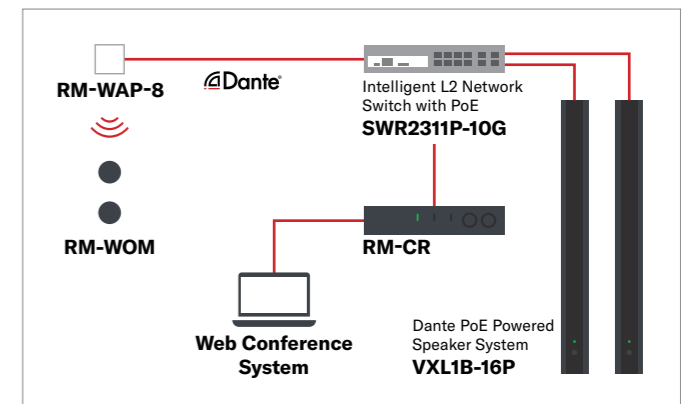
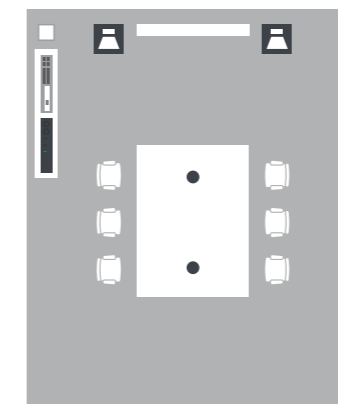
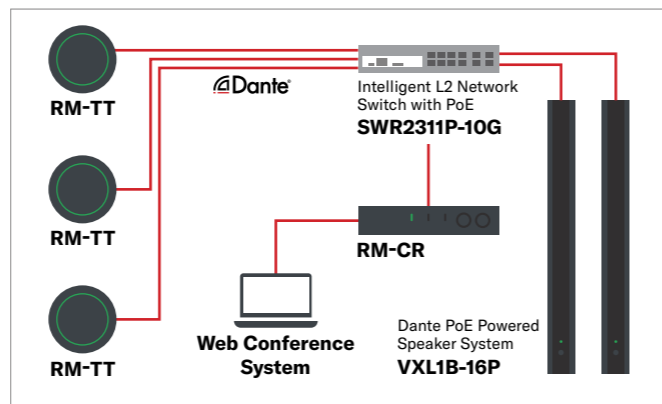
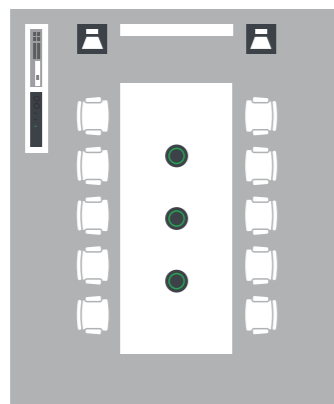
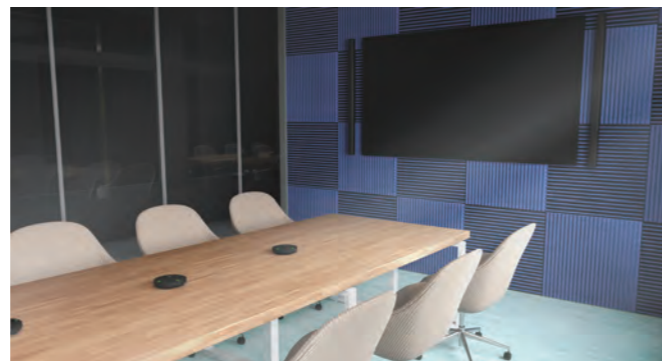

# Customization

The new Yamaha ADECIA microphone components can also be integrated with other Yamaha or third party components for required solutions with the open API.

\* ProVisionaire or RM Device Finder may be required, please refer to the reference guide for details.

- ProVisionaire: customizable control panel software for Yamaha PA systems
- RM Device Finder: application software for searching RM components in the network

## Customization Options

The open interfaces and standards based integration options of the ADECIA components allow easy integration in other customized solutions. Some examples of that are:

- Expand the number of microphones beyond the number supported within the ADECIA solution
- Expand solutions to peripheral devices not part of the ADECIA family, e.g. amplifiers or speakers

## RM-CG System Example

### Yamaha Customized Configuration Example

- Ceiling Array Microphone **RM-CG**
- Intelligent L2 Network Switch with PoE **SWR2311P-10G**
- Signal Processor **MTX/MRX Series**
- Power Amplifier **XMV4140-D**
- Ceiling Speaker **VXC4W**
- Speaker System **VXS5W**
- Customizable Control Panel **ProVisionaire**
- USB Audio Interface

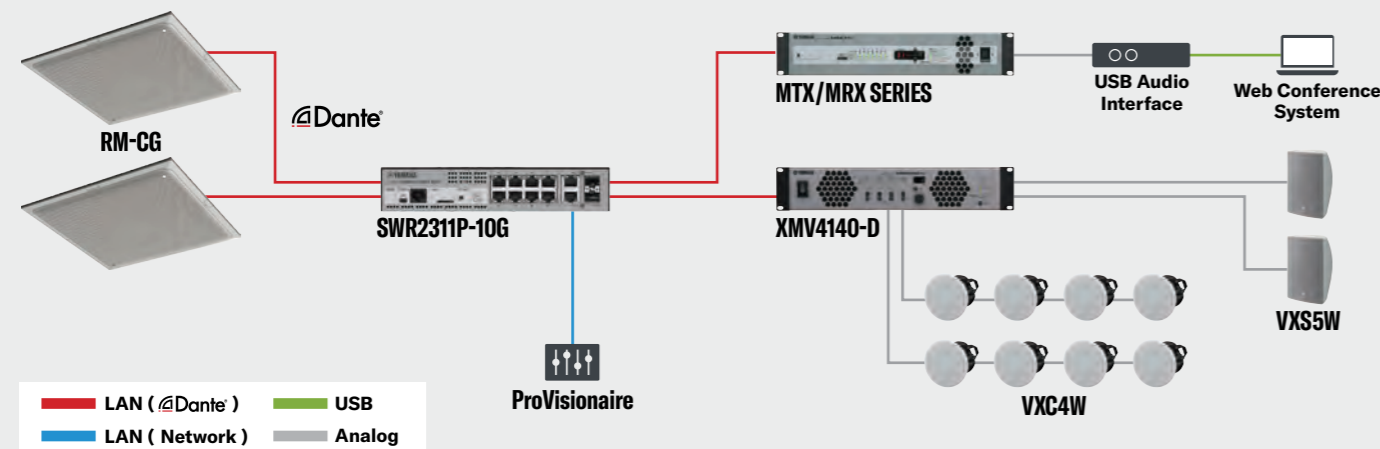

## RM-TT System Example

### Yamaha Customized Configuration Example

- Tabletop Array Microphone **RM-TT**
- Intelligent L2 Network Switch with PoE **SWR2311P-10G**
- Simple L2 Network Switch with PoE **SWR2100P-5G**
- Signal Processor **MTX/MRX Series**
- Power Amplifier **XMV4140-D**
- Ceiling Speaker **VXC4W**
- Speaker System **VXL1W-16**
- Customizable Control Panel **ProVisionaire**
- USB Audio Interface

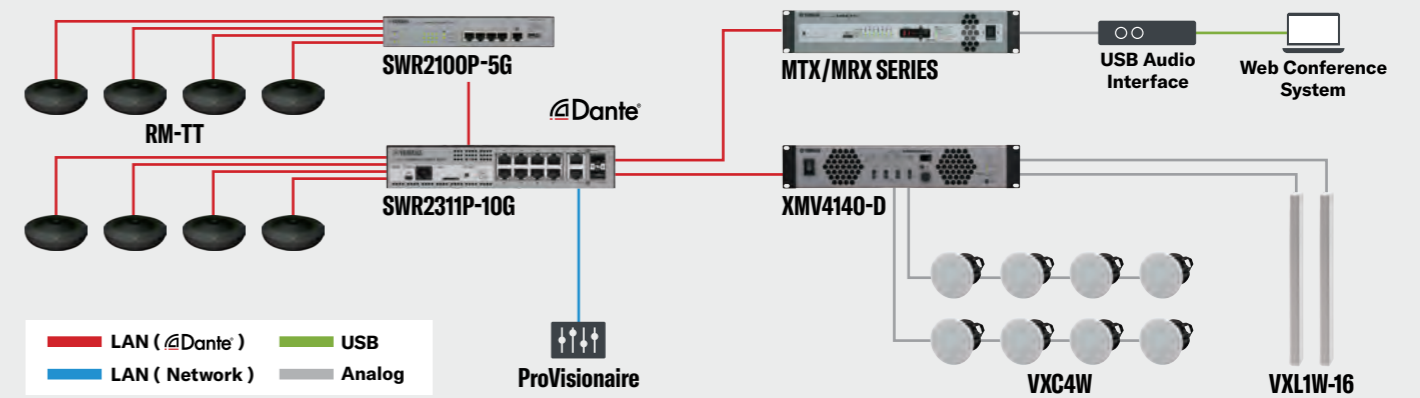

## RM-W System Example

### Yamaha Customized Configuration Example

- Wireless Microphone System **RM-W Series**
- Intelligent L2 Network Switch with PoE **SWR2311P-10G**
- Signal Processor **MTX/MRX Series**
- Power Amplifier **PX3**
- Speaker System **VXL1W-24**
- Customizable Control Panel **ProVisionaire**
- USB Audio Interface

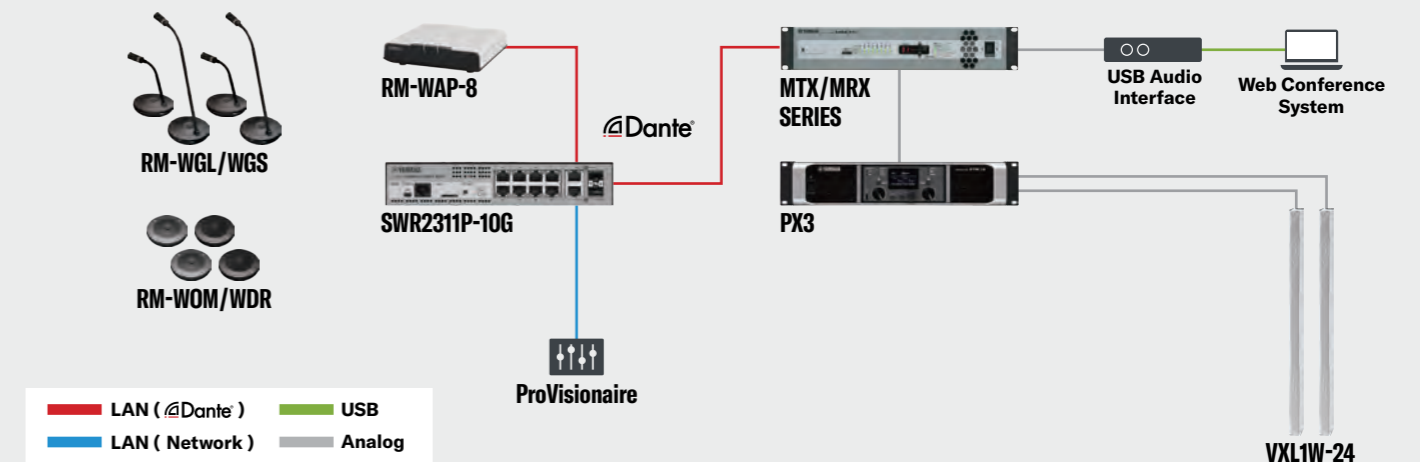

# Ceiling Array Microphone RM-CG



Ceiling Array Microphone  
**RM-CG**

A ceiling array microphone equipped with unique audio signal processing technology that enables high-quality communication

- “Multi-beam Tracking” that scans for human voice and tracks simultaneous speech allowing for lively conversations
- Utilizes innovative Yamaha technologies like Adaptive Echo Canceller, Auto Gain Control, Noise Reduction, and Dereverberation
- Automatic detection and configuration with Remote Conference Processor RM-CR
- Standard network audio support for “Dante”
- Utilizes one PoE+ network cable connection avoiding troublesome wiring and enabling audio control via Dante
- Supports 3 types of mounting methods for use with a variety of ceiling conditions



## Frequency Response

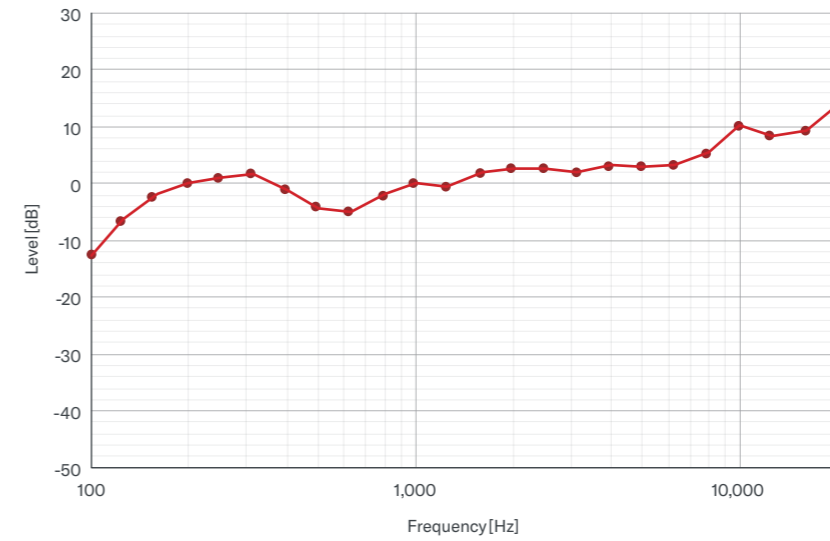

## Directional Characteristics

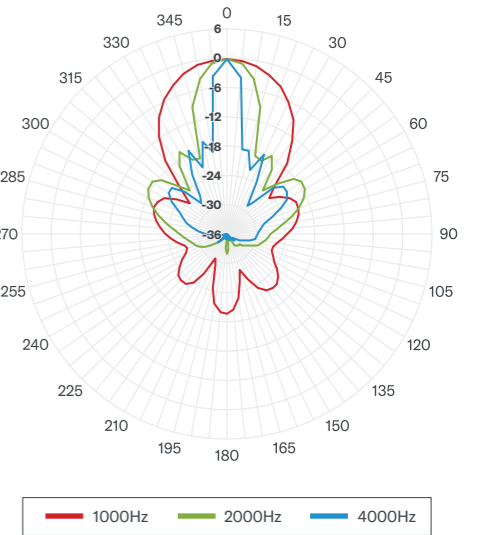

## External View

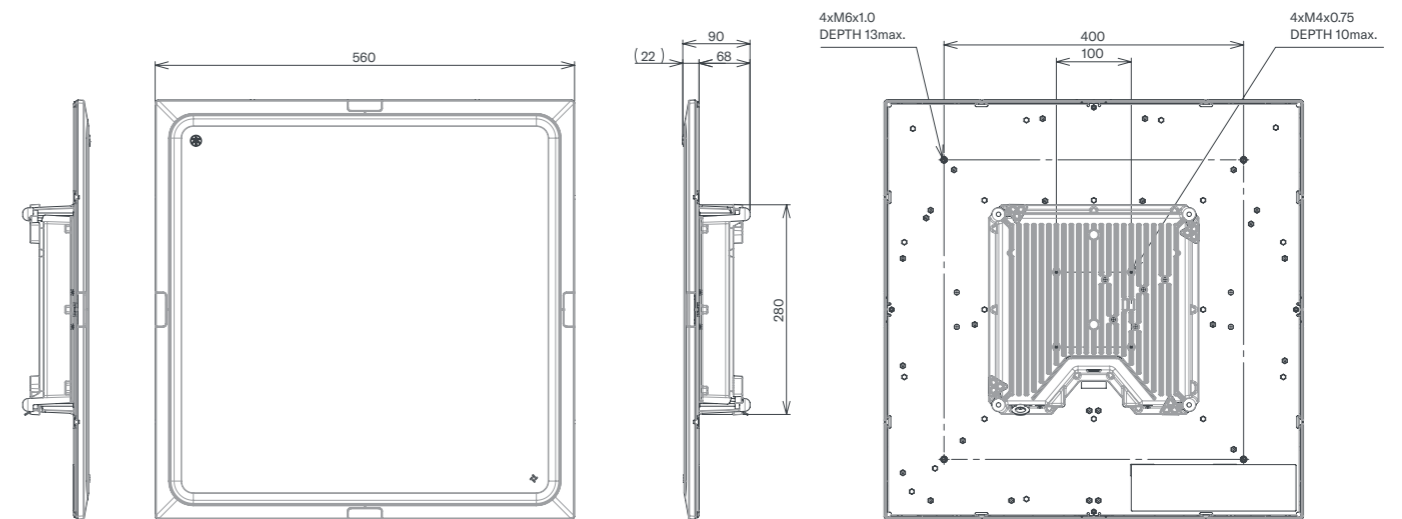

Unit : mm



# Tabletop Array Microphone RM-TT

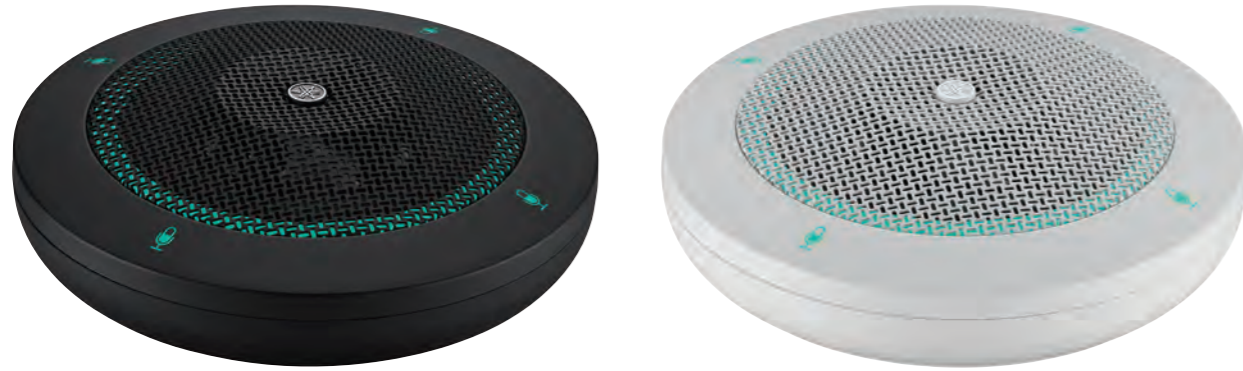

Tabletop Array Microphone  
**RM-TT**

Tabletop array microphones provide a comfortable sound environment with no configuration needed

- Auto Voice Tracking allows for flexible room layout and participant positioning
- 6 types of microphone directivity to choose from, depending on your environment and audio needs
- Achieves comfortable sound quality using the integrated Adaptive Echo Canceller, Auto Gain Control, Noise Reduction, and Dereverberation
- When using Auto Voice Tracking, RM-CR automatically selects the microphone element that provides the best audio signal of the voice
- Standard network audio support for "Dante"
- Utilizes one PoE+ network cable connection avoiding wiring problems and enabling audio control via Dante
- The included accessory allows for fixed installations of the microphones on tables



## Frequency Response

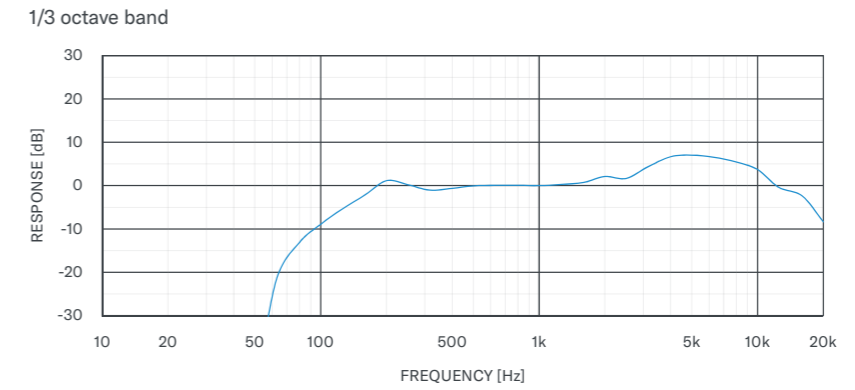

## Directional Characteristics

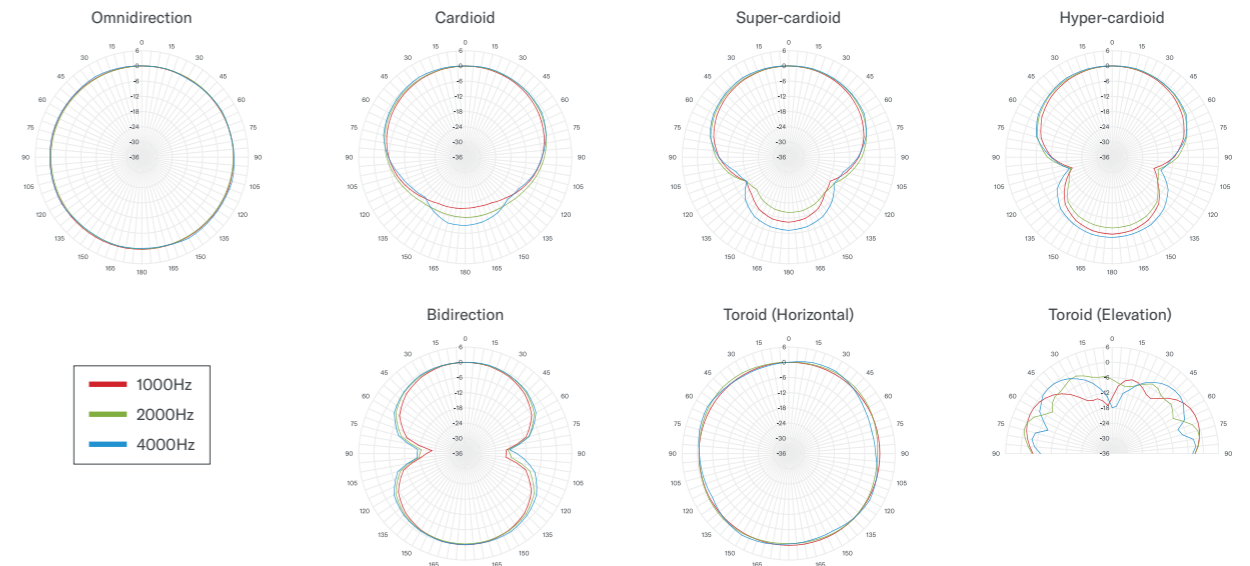

## External View

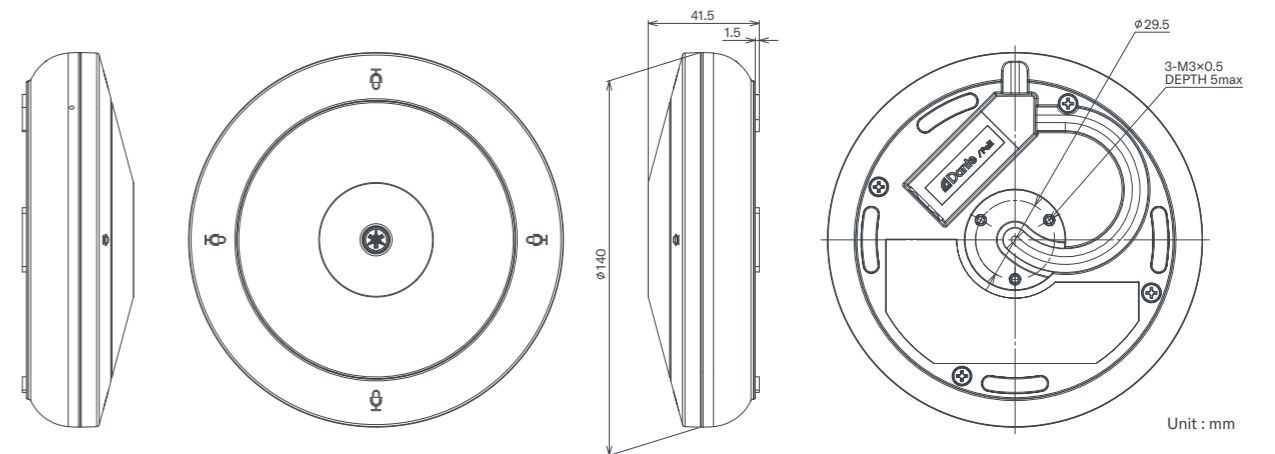

# Wireless Microphone System RM-W Series



Wireless Microphone System

## RM-W Series

Flexible wireless microphones system customized to your use case

- Wireless system using 1.9GHz, composed of access point, microphone, and charging station
- The access point supports 8 channels
- Available microphone formfactors: 6" (15 cm) gooseneck, 12" (30 cm) gooseneck, omnidirectional boundary, and cardioid directional boundary
- Approximately 20 hours of continuous microphone operation time using the included Li-ion battery
- Standard network audio support for "Dante"
- Utilizes one PoE+ network cable connection avoiding wiring problems and enabling audio control via Dante
- The Web UI Setup Wizard allows for effortless configuration, microphone pairing, audio routing, and other system management



## Frequency Response

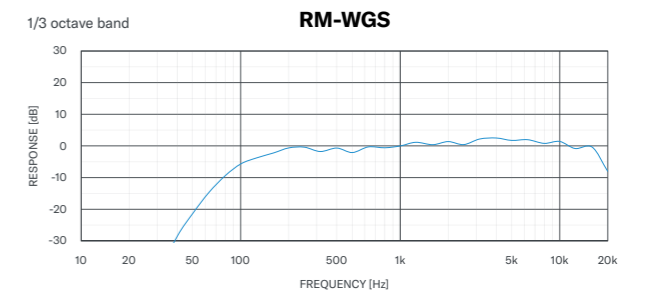
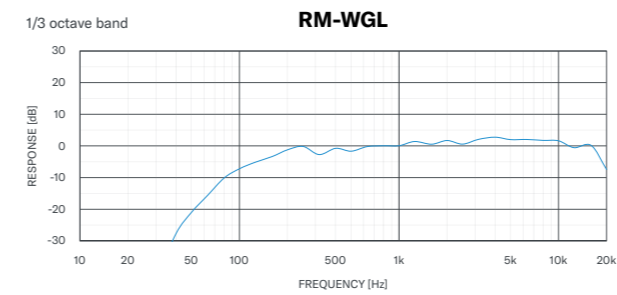
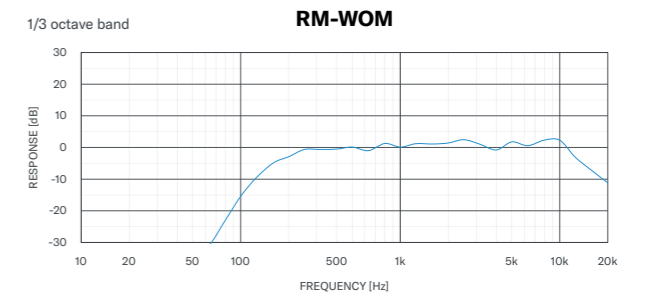
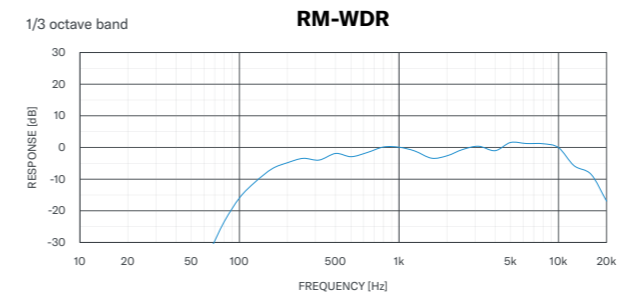

## Directional Characteristics

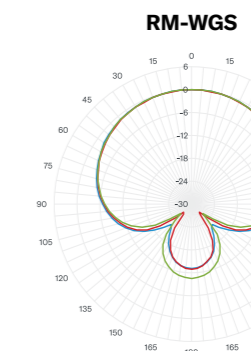
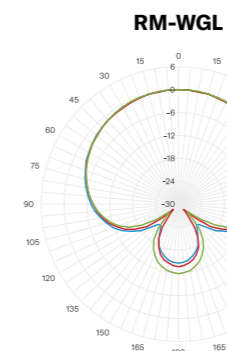
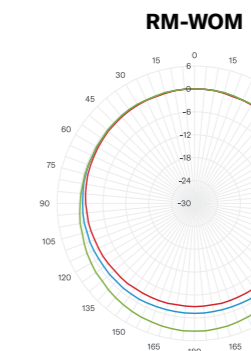
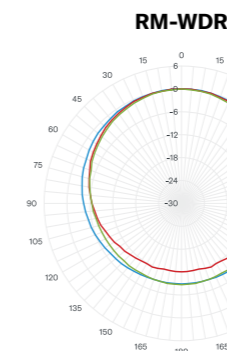
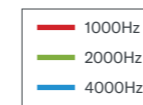

# Wireless Microphone System RM-W Series



Wireless Directional Tabletop Microphone

**RM-WDR**



Wireless Omnidirectional Tabletop Microphone

**RM-WOM**



Wireless 12inch Gooseneck Microphone

**RM-WGL**



Wireless 6inch Gooseneck Microphone

**RM-WGS**

- Wireless microphones using 1.9GHz band
- Available microphone formfactors: 6" (15 cm) gooseneck, 12" (30 cm) gooseneck, omnidirectional boundary, and cardioid directional boundary
- Approximately 20 hours of continuous microphone operation time using the included Li-ion battery

**RM-WDR**

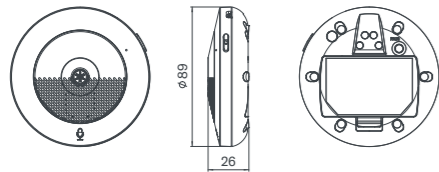

**RM-WOM**

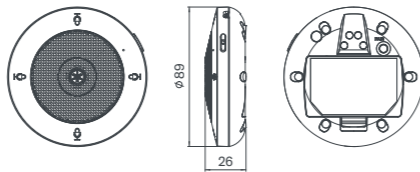

**RM-WGL**

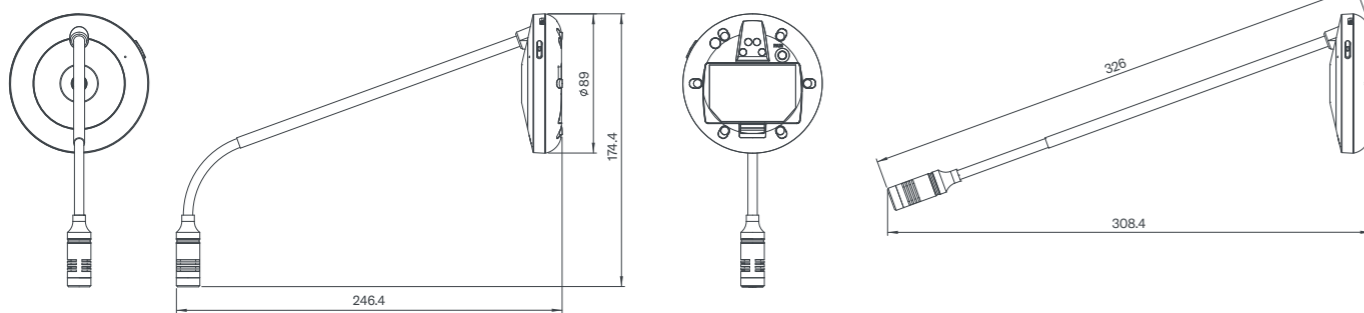

**RM-WGS**

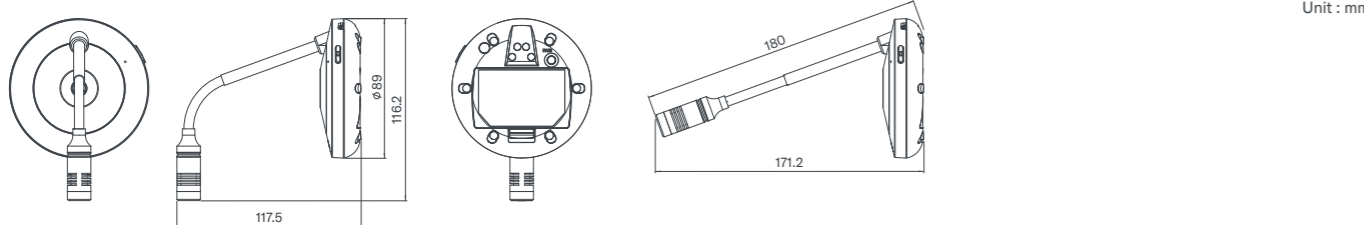

Unit : mm



8 Channel Wireless Access Point

**RM-WAP-8**

- Access point of 1.9GHz band wireless microphone system
- Supports 8 channels
- Dante audio/control reception and PoE power are provided through a single network cable

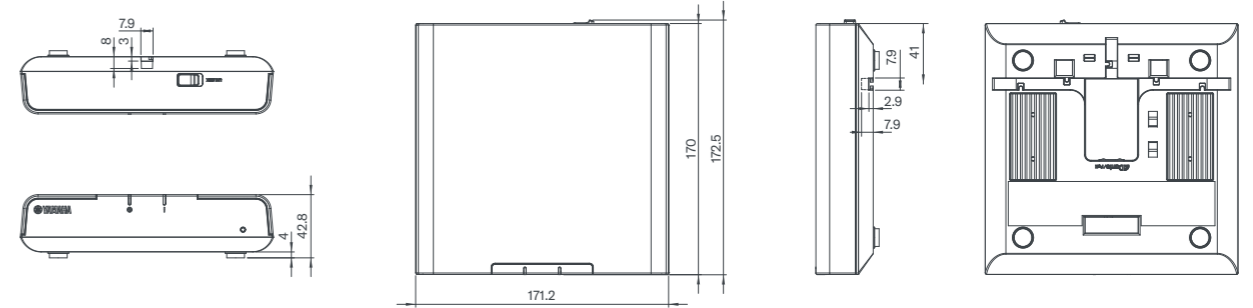

Unit : mm



Microphone Charging Station

**RM-WCH-8**

- Microphone charger for the wireless microphones in the RM series
- Up to 8 microphones can be charged at a time
- Charge time 5 hours to full charge

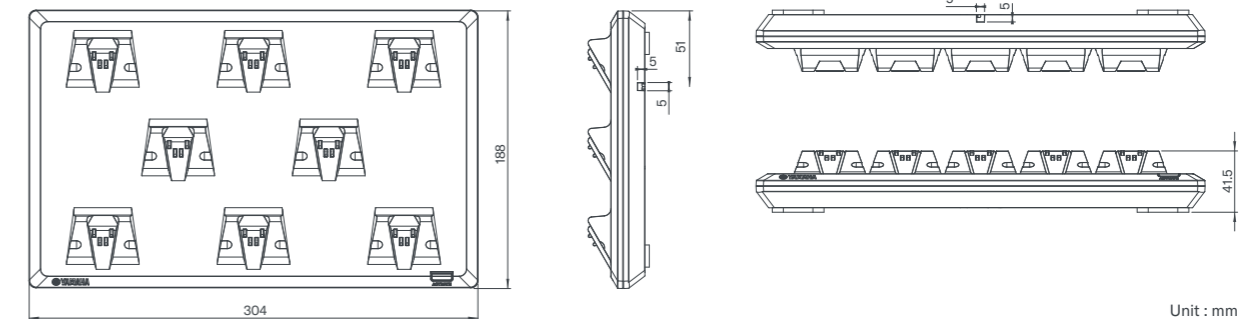

Unit : mm

# Remote Conference Processor RM-CR



Remote Conference Processor

## RM-CR

Signal processor at the heart of the ADECIA

- Up to 4 units of RM-CG, or 14 (\*) RM-TT microphones, or 2 RM-WAP-8 access points, and 2 VXL1-16P speakers can be connected to the processor via PoE switch
- Automatically recognizes connected devices on the same network for audio routing
- Equipped with the Auto Tuning functions that automatically measure and provide the optimum sound settings for the environment
- Includes the Auto Mixer functions that automatically optimizes the mixing balance of audio input via Dante
- Supporting various input/output connections such as USB, VoIP, analog audio, and Bluetooth
- Standard network audio support for "Dante"; all compatible devices can be connected with network cables

\* Without VXL1-16P, up to 16.



## Connections

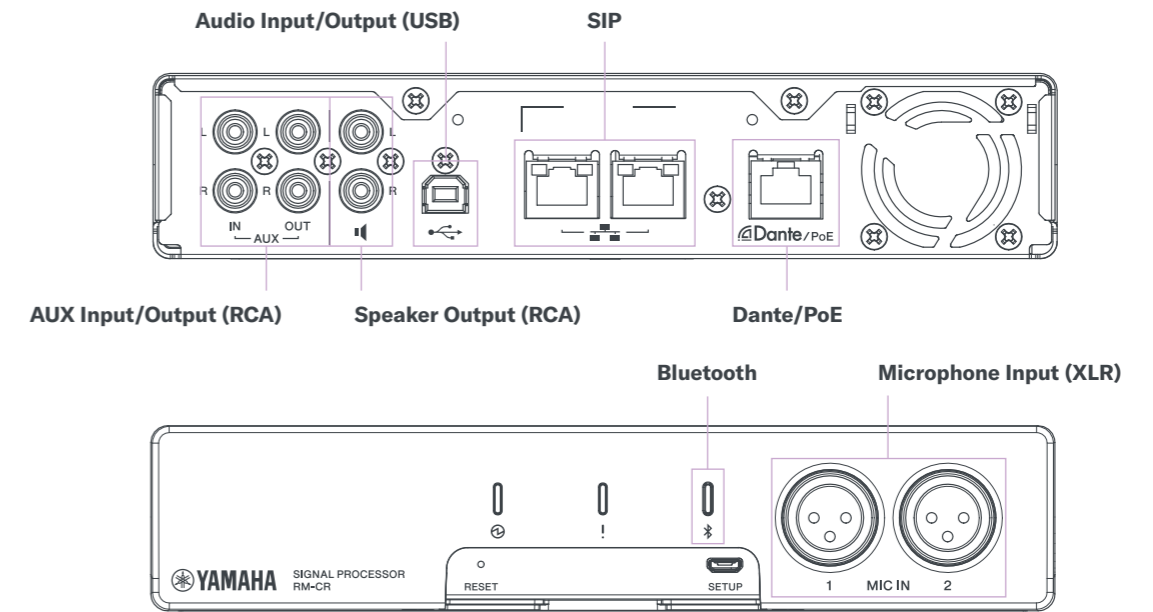

## External View

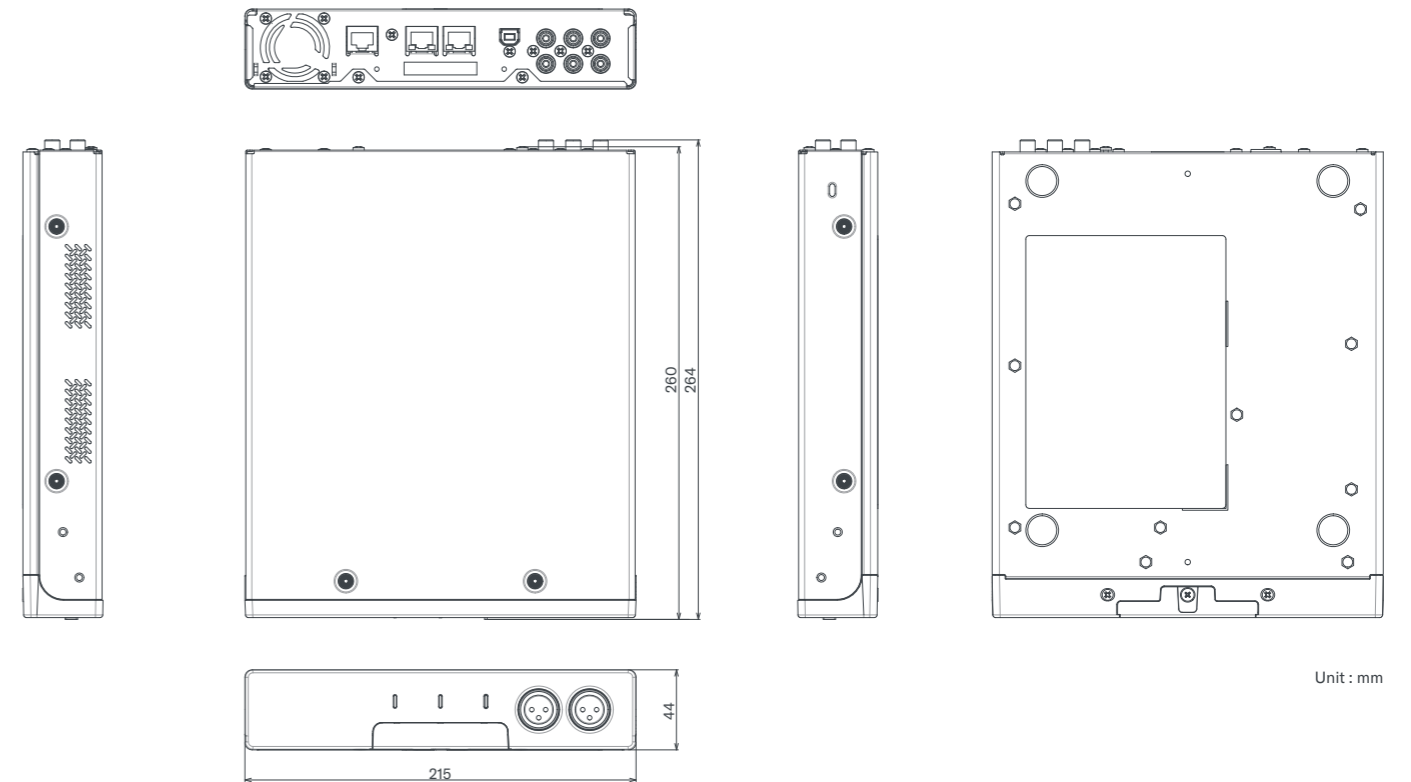

# Specifications

## RM-CG Specifications

General	Dimensions	560 (W) x 90 (H) x 560 (D) mm (including protrusion/microphone panel: 22 mm)		
	Weight	5.6 kg		
	Power Requirements	PoE (IEEE 802.3af)		
	Maximum Power Consumption	7.2 W		
	Connector	RJ-45		
	In Operation	Temperature	0°C - 40°C	
		Humidity	30% - 90% (no condensation)	
	Storage	Temperature	-20°C - 60°C	
		Humidity	20% - 90% (no condensation)	
	Indicators	Front indicator (Mute/Unmute & Status), Network port indicator		
Mount	Ceiling mount, Wire mount, VESA mount			
Network	Maximum Device Number with RM-CR	4		
	Accessories (* Including a spare respectively)	Construction description, (Guarantee), Grille x 1, Screws for grille (M3 x 8 mm) x 5, Screw cover x 4, Cutting template x 1, C ring x 1, Screws for C ring x 2, Hanger angle x 1, Screws for hanger angle (M4 x 20 mm) x 5, Terminal cover x 1, Safety wire x 1, Binding band x 1, Clamp plate x 2		
	Dust Protection	IP5X for dust protection (with terminal cover)		
	Plenum Rating	UL2043 (with terminal cover)		
	Ethernet	Dante, Remote Control, Web UI, PoE		
	Cable Requirements	CAT5e or higher (STP)		
	Audio I/O	Dante	1 in/2 out	
		Sampling Rate	48 kHz	
	Bit Depth	24 bit		
	Latency	58 ms (including signal processing)		
Frequency Response	160 Hz - 16 kHz (-10 dB)			
Audio	Maximum Input Level of SPL (0 dBFS)	117.8 dB SPL		
	Self Noise	-0.8 dBA SPL		
	SN Ratio (Ref. 94 dB SPL at 1 kHz)	94.8 dBA		
	Sensitivity	-23.8 dBFS/Pa		
	Dynamic Range	118.6 dBA		
	Signal Processing	Multi-beam Tracking, Adaptive Echo Cancellor, Noise Reduction, Dereverberation, Auto Mixer, Auto Gain Control, Parametric EQ, Output Gain Adjustment		

## RM-TT Specifications

General	Dimensions	140 (W) x 41.5 (H) x 140 (D) mm		
	Weight	310 g		
	Power Requirements	PoE (IEEE 802.3af)		
	Maximum Power Consumption	4.5 W		
	Connector	RJ-45		
	In Operation	Temperature	0°C - 40°C	
		Humidity	30% - 90% (no condensation)	
	Storage	Temperature	-20°C - 60°C	
		Humidity	20% - 90% (no condensation)	
	Indicators	Mute indicator (Mute/Unmute), Status indicator, Network port indicator		
Maximum Device Number with RM-CR	14 (without VX1-16P, up to 16)			
Network	Accessories	Installation manual, Tabletop mounting adapter, Screw for mounting x 3, Spacer x 3		
	Ethernet	Dante, Remote Control, Web UI, PoE		
	Cable Requirements	CAT5e or higher (STP)		
	Audio I/O	Dante	1 in/2 out	
		Sampling Rate	48 kHz	
	Bit Depth	24 bit		
	Latency (including signal processing)	46 ms (except for toroidal directivity) 50 ms (for toroidal directivity)		
	Frequency Response	160 Hz - 16 kHz (-10 dB)		
	Maximum Input Level of SPL (0 dBFS)	106.8 dB SPL		
	Self Noise	6.3 dBA SPL		
Audio	SN Ratio (Ref. 94 dB SPL at 1 kHz)	87.7 dBA		
	Sensitivity	-12.8 dBFS/Pa		
	Dynamic Range	100.5 dBA		
	Signal Processing	Auto Voice Tracking, Selectable Polar Pattern (Cardioid, Hyper-cardioid, Super-cardioid, Omnidirectional, Bidirectional, Toroid), Adaptive Echo Cancellor, Noise Reduction, Dereverberation, Auto Mixer, Auto Gain Control, Parametric EQ, Output Gain Adjustment		

## RM-WDR/RM-WOM Specifications

	RM-WDR	RM-WOM		
General	Dimensions	89.0 (W) x 26.0 (H) x 89.0 (D) mm (including rubber foot)		
	Weight	130 g (including battery)	126 g (including battery)	
	Power Requirements	Rechargeable Li-ion Battery 3.6 V 2350 mA/h		
	Maximum Power Consumption	5.0 V 0.7 A		
	Connector	USB Type-C (for battery charging) x 1, Charger I/F (4pin) x 1		
	Battery	Talk Time	Approximately 20 hours (power on)	
		Standby Time	7 days	
		Charge Time	Full charging: 5 hours, 80% charging: 3 hours	
	In Operation	Temperature	0°C - 40°C	
		Humidity	20% - 85% (no condensation)	
In Charging	Temperature	5°C - 40°C		
	Humidity	20% - 85% (no condensation)		
Storage	Temperature	-20°C - 60°C		
	Humidity	10% - 90% (no condensation)		
Indicators	Microphone indicator (3 colors) x 1, Battery indicator (3 colors) x 1			
Buttons	Microphone button x 1, Battery button x 1, PAIR button x 1			
Accessories	Battery (RM-WBT) x 1, Owner's manual x 1			
Options	Replacement Battery RM-WBT			
Audio	Audio I/O	Dante	1 in/2 out	
		Sampling Rate	48 kHz	
	Bit Depth	24 bit		
	Latency	110 ms nominal (with signal processing in High Quality mode)		
	Frequency Response	160 Hz - 16 kHz		
	Maximum Input Level of SPL (0dBFS)	100.2 dB SPL	99.4 dB SPL	
	Self Noise	-24.7 dBA SPL	-23.0 dBA SPL	
	SN Ratio (Ref. 94dB SPL at 1kHz)	118.7 dBA	117.0 dBA	
	Sensitivity	-6.2 dBFS/Pa	-5.4 dBFS/Pa	
	Dynamic Range	124.9 dBA	122.4 dBA	
Directivity	Unidirectional	Omnidirectional		

## RM-WGL/RM-WGS Specifications

	RM-WGL	RM-WGS		
General	Dimensions	89.0 (W) x 308.4 (H) x 89.0 (D) mm		
	Weight	152 g (including battery)	140 g (including battery)	
	Power Requirements	Rechargeable Li-ion Battery 3.6 V 2350 mA/h		
	Maximum Power Consumption	5.0 V 0.7 A		
	Connector	USB Type-C (for battery charging) x 1, Charger I/F (4pin) x 1		
	Battery	Talk Time	Approximately 20 hours (power on)	
		Standby Time	7 days	
		Charge Time	Full charging: 5 hours, 80% charging: 3 hours	
	In Operation	Temperature	0°C - 40°C	
		Humidity	20% - 85% (no condensation)	
In Charging	Temperature	5°C - 40°C		
	Humidity	20% - 85% (no condensation)		
Storage	Temperature	-20°C - 60°C		
	Humidity	10% - 90% (no condensation)		
Indicators	Microphone indicator (3 colors) x 1, Ring indicator (3 colors) x 1, Battery indicator (3 colors) x 1			
Buttons	Microphone button x 1, Battery button x 1, PAIR button x 1			
Accessories	Battery (RM-WBT) x 1, Owner's manual x 1			
Options	Replacement Battery RM-WBT			
Audio	Audio I/O	Dante	1 in/2 out	
		Sampling Rate	48 kHz	
	Bit Depth	24 bit		
	Latency	30 ms - 35 ms nominal (without signal processing in High Quality mode) 110 ms nominal (with signal processing in High Quality mode)		
	Frequency Response	160 Hz - 16 kHz		
	Maximum Input Level of SPL (0dBFS)	106.2 dB SPL		
	Self Noise	-19.3 dBA SPL		
	SN Ratio (Ref. 94dB SPL at 1kHz)	113.3 dBA		
	Sensitivity	-12.2 dBFS/Pa		
	Dynamic Range	125.5 dBA		
Directivity	Unidirectional			

# Specifications

## RM-WAP-8 Specifications

General	Dimensions		171.2 (W) x 42.8 (H) x 172.5 (D) mm	
	Weight		650 g (including mounting bracket)	
	Power Requirements		PoE Class 3 (IEEE 802.3af)	
	Maximum Power Consumption		48.0 V 0.2 A	
	Connector	RJ-45		
		In Operation	Temperature	0°C - 40°C
	Storage	Humidity	20% - 85% (no condensation)	
		Temperature	-20°C - 60°C	
	Indicators	Humidity	10% - 90% (no condensation)	
		Power indicator (3 colors) x 1, Status indicator (3 colors) x 1		
	Buttons		Reset button x 1	
	Mount		Wall mount, Ceiling mount (with bracket), Flat placing	
	Maximum Device Number with RM-CR		2	
Accessories		Owner's manual x 1, Mounting bracket x 1		
Network	Ethernet		Dante, Remote Control, Web UI, PoE	
	Cable Requirements		CAT5e or higher (STP)	
Audio	Audio I/O	Dante	1 in/8 out	
	Signal Processing		Adaptive Echo Canceller, Noise Reduction, Dereverberation, Auto Gain Control, Parametric EQ, Output Gain Adjustment	

## RM-WCH-8 Specifications

General	Dimensions		304.0 (w) x 41.5 (H) x 188.0 (D) mm (including rubber foot)	
	Weight		800 g	
	Power Requirements		DC IN (16 V, 2.4 A)	
	Maximum Power Consumption		16.0 V 2.0 A	
	Connector	DC IN 16V		
		In Operation	Temperature	0°C - 40°C
	Storage	Humidity	20% - 85% (no condensation)	
		Temperature	-20°C - 60°C	
	In Charging	Humidity	10% - 90% (no condensation)	
		Temperature	5°C - 40°C	
	Storage	Humidity	20% - 85% (no condensation)	
		Temperature	-20°C - 60°C	
	Indicators	Humidity	10% - 90% (no condensation)	
ACTIVATE indicator (3 colors) x 1				
Buttons		ACTIVATE button x 1, PAIR button x 1		
Accessories		Owner's manual x 1, AC adapter x 1, Power cable x 1 (for US)/3 (for Europe)		

## RM-CR Specifications

General	Dimensions		215 (W) x 44 (H) x 260 (D) mm	
	Weight		1.6 kg	
	Power Requirements		PoE+ (IEEE 802.3at, LLDP)	
	Maximum Power Consumption		15.0 W	
	In Operation	Temperature	0°C - 40°C	
		Humidity	30% - 90% (no condensation)	
	Storage	Temperature	-20°C - 60°C	
		Humidity	20% - 90% (no condensation)	
	Indicators		Power indicator, Status indicator, Bluetooth indicator, Network port indicator x 3	
	Accessories		Installation manual, USB cable (A-B) 5 m (16.4 ft), USB cable (A-microB) 1 m (3.3 ft), Rubber foot x 4, Access panel	
	Options		Rack Mount Kit RM-MTL, Table Mount Kit RM-MRK	
	Network	Ethernet1		Dante, Remote Control, Web UI, PoE+
		Ethernet2/Ethernet3		Corporate Network, Remote Control, SIP, Web UI
USB Network (Front)		USB2.0, Network Class, Web UI, Fixed IP		
Cable Requirements		Ethernet1/2/3: CAT5e or higher (STP) USB Network : USB Cable (A-microB)		
Audio	Audio I/O	Dante	16 in/16 out	
		USB	USB2.0, Audio Class 1.0, Input: 2ch, Output: 2ch @48 kHz	
	Microphone Input	XLR Balanced, Input: 2ch		
	AUX	RCA Unbalanced (Line Level), Input: 2ch, Output: 2ch		
	Speaker Out	RCA Unbalanced (Line Level), Output: 2ch		

Audio	Audio I/O	Bluetooth	Version 4.2 Supported Profiles: HFP (1.6), A2DP, AVRCP Supported Codec: CVSD, SBC, mSBC Wireless Output: Class2 Maximum Communication Distance: 10 m (32.8 ft) (no obstacles) Radio Frequency (Operational Frequency): 2,402 MHz - 2,480 MHz Maximum Output Power (EIRP): 4.0 dBm (2.5 mW)
		SIP	Call Handling: Dial, Answer, Hold, Resume, Forwarding, Do not disturb, Redial, Call timer, Call ID, Voice mail notifications (switch configured) Call Bridging: Supports bridging SIP, USB, BT and AUX calls. Join, Split, Hold, Resume, 5+1 lines: up to 2 SIP calls, 1 USB call, 1 Bluetooth call, 1 AUX, Plus the user Codecs: G.711, G.722HD, G.729ab, G.726 DTMF Support: RTP event, SIP in-band, SIP info package Security: SRTP support (RFC 1889), IETF SIP support (RFC 3261 and companion RFCs)
		Sampling Rate	48 kHz
		Bit Depth	24 bit
		Latency	8 ms (Dante In to USB Out, includes signal processing)
		Frequency Response	20 Hz - 20 kHz

## RM-WBT Specifications

General	Dimensions		34.95 (W) x 11.15 (H) x 52.5 (D) mm	
	Weight		42 g	
	Voltage		3.6 V	
	Nominal Capacity		2,350 mA/h	
	Maximum Charge Current		1.59 A	
	Maximum Charge Voltage		4.20 V	
	Maximum Discharge Current		2.30 A	
	In Operation	Temperature	0°C - 40°C	
		Humidity	20% - 85% (no condensation)	
	Storage	Temperature	-20°C - 60°C	
		Humidity	10% - 90% (no condensation)	
	Accessories		Safety brochure x 1	

## RM-W Series Common Specifications

Wireless	Radio Method	1.9 GHz DECT standard
	Radio Frequency Range	[USA and Canada]
		1920.0 MHz - 1930.0 MHz
		[EU, Australia, New Zealand, Norway and UK]
	Maximum RF Power Level (EIRP)	[USA and Canada]
		20.1 dBm
[EU, Australia, New Zealand, Norway, Sweden, Finland, Denmark and UK]		
Maximum Coverage Distance	50 m (depends on the usage environment)	
Encryption	AES (256-bit)	

## RM-CR Analog Input Characteristics

Input Terminal	Input Level		Connector
	Nominal	Max. before Clip	
MIC IN 1/2	-46 dBu	-26 dBu	XLR-3-31 (Balanced)
AUX IN L/R	-14 dBV	+6 dBV	RCA Pin

## RM-CR Analog Output Characteristics

Output Terminal	Source Impedance	For Use with Nominal	Output Level		Connector
			Nominal	Max. before Clip	
AUX OUT L/R	1 kΩ	10 kΩ	-14 dBV	+6 dBu	RCA Pin
SP OUT L/R	1 kΩ	10 kΩ	-14 dBV	+6 dBV	RCA Pin

## Accessories/Options

---



Replacement Battery  
**RM-WBT**

Replacement battery for RM-WDR, RM-WOM, RM-WGL, and RM-WGS.

---



Rack Mount Kit  
**RM-MRK**

Mount kit for mounting the Remote Conference Processor RM-CR in a 19-inch rack (EIA standard).

---



Table Mount Kit  
**RM-MTL**

Mount kit for mounting the Remote Conference Processor RM-CR under the table.

---



Intelligent L2 Network Switch with PoE  
**SWR2311P-10G**

An intelligent L2 switch that has the optimal functions for Dante and can supply PoE+ to up to 8 connected devices.  
Maximum 30W can be supplied from each PoE-compliant port (240W in total).

---



Simple L2 Network Switch with PoE  
**SWR2100P-10G**  
**SWR2100P-5G**

A simple L2 switch that has the optimal functions for Dante and can supply PoE and PoE+ to connected devices.  
SWR2100P-10G has 9 ports available for PoE power supply and can supply maximum 30W per port (70W in total).  
SWR2100P-5G has 4 ports available for PoE power supply and can supply maximum 30W per port (70W in total).

---



Dante PoE Powered Speaker System  
**VXL1B-16P** (Black)  
**VXL1W-16P** (White)

A Dante powered speaker by PoE power supply.

---

# Case Studies

## KOKUYO Co., Ltd.

KOKUYO's Furniture Business Division provides a wide range of office furniture such as desks, chairs, and storage, as well as furniture for education, medical care, and public facilities, in addition to solution-oriented services such as office relocation. Although many Japanese companies have been hastily introducing measures to address the recent COVID-19 pandemic, KOKUYO is seeking to soon introduce new ways of working and office styles that are mindful of protecting against infectious diseases. Yamaha's ADECIA one-stop sound solution for remote conferencing has been introduced in the conference rooms and multipurpose spaces of KOKUYO's Shinagawa Live Office, which reopened in February 2021 after renovations.



Wide view of Meeting Room 5 (equipped with the ADECIA and AIRTRIEVE systems)

### With the COVID-19 Pandemic, Clients Seek to Achieve the Right Balance of Employee Safety and Security with Communication

Before the COVID pandemic, work style reform (notions such as optimizing work-life balance) was a major theme, but now it's more about employee safety and security, and coordinating between remote work and office work. In such a situation, KOKUYO decided to rapidly implement some plans to ensure safety and security while striving for innovation through promoting collaboration, such as AIRTRIEVE airborne droplet suction table for meeting rooms, which were installed in several meeting rooms, including this board meeting room.



The Shinagawa Live Office reopened in February 2021 after renovations

For the boardroom where board members gather to discuss important company matters, and their meeting rooms for visitors where they meet VIPs of crucial importance to their business, such as their clients and business partners, appropriate equipment were required to enable all attendees to concentrate on the conversation in comfort.



Board meeting room equipped with the ADECIA and AIRTRIEVE system

### The ADECIA Ceiling Microphone Creates Spaces that Allow You to Concentrate on Conversation

In the case of meeting rooms used only for communication among employees, it's not too much of a concern if online conferencing microphones and cables are placed randomly onto tables, but this approach is simply not suitable for really special places of communication. One main reason for introducing ADECIA, which features panel-shaped microphones installed on the ceiling, was that it keeps the tabletop as clear and clean as possible.

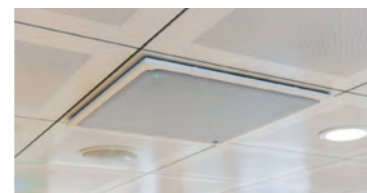

Ceiling Array Microphone RM-CGW installed on the boardroom ceiling

Most conference tables are designed to be installed such that cabling is as inconspicuous as possible by taking out cables from a cabling space installed in the central section of the tabletop — however, when using the AIRTRIEVE system, the air intake port occupies that position, so cables need to be run from the seating area instead, which creates hindrances for attendees and does not look attractive. Thanks to ADECIA, they were able to achieve the ultimate clean look without microphones or connection cables being visible in any way.

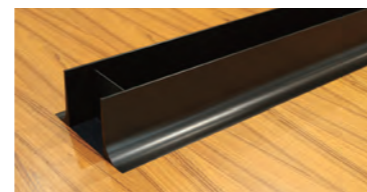

The AIRTRIEVE system can reduce airborne viruses in meeting rooms by about 99% in 5 minutes

Since the purpose of a meeting is to watch facial expressions and read the spaces between overt remarks in order to achieve deeper communication, an environment such as this meeting room, where the table is free of clutter and you don't have to stay constantly aware of the position and distance of the microphone, is simply ideal. The design of the ceiling microphone is also highly evaluated. Not only is it installed out of sight on the ceiling — it also blends into the ceiling without calling attention to itself.

### Introducing ADECIA Has Greatly Improved the Voice Quality and Practical Usability of Remote Conferences

The boundary microphones used previously had some problems in picking up sounds, and it was difficult to hear people with soft voices or who were distant from the microphone. They constantly had to physically hand the microphone around among speakers, turn to face the microphone, stay aware of the position of the microphone, and so on. Every time a board meeting was held, they really wanted to avoid this sort of situation. This was one of the reasons they decided to introduce ADECIA.

With ADECIA, the microphones installed in the ceiling instantly and automatically detect the direction of the sound source and pick up the sound, so meeting attendees can concentrate on the conversation without being aware of the microphone at all. Thanks to an auto gain control that distinguishes the human voice and adjusts the volume precisely, everyone present is able to hear clearly, regardless of seating position or speaking volume.

They also highly evaluated the noise reduction function. The AIRTRIEVE system, which is equipped with a powerful air purification unit, inevitably generates some intake and exhaust noise. The high-performance noise reduction function of ADECIA is effective in reducing this sort of low-frequency noise to a much less noticeable level, while clearly conveying conversational voices.

They also introduced ADECIA in a multipurpose space that contains no meeting table. Small-scale seminars and training will be held here, and with ADECIA, there is no need to adjust the arrangement or layout of microphones according to the number of users, and to worry about anyone tripping over cables when arranging the room layout. Thanks to the microphones that actively track multiple sound sources, sound can be picked up clearly no matter where the speaker is seated, which is a major advantage in a space like this.



Wide view of Meeting Room 5 (equipped with the ADECIA and AIRTRIEVE systems)



Wide view of Meeting Room 3

### Layout of the ADECIA System Arranged by KOKUYO

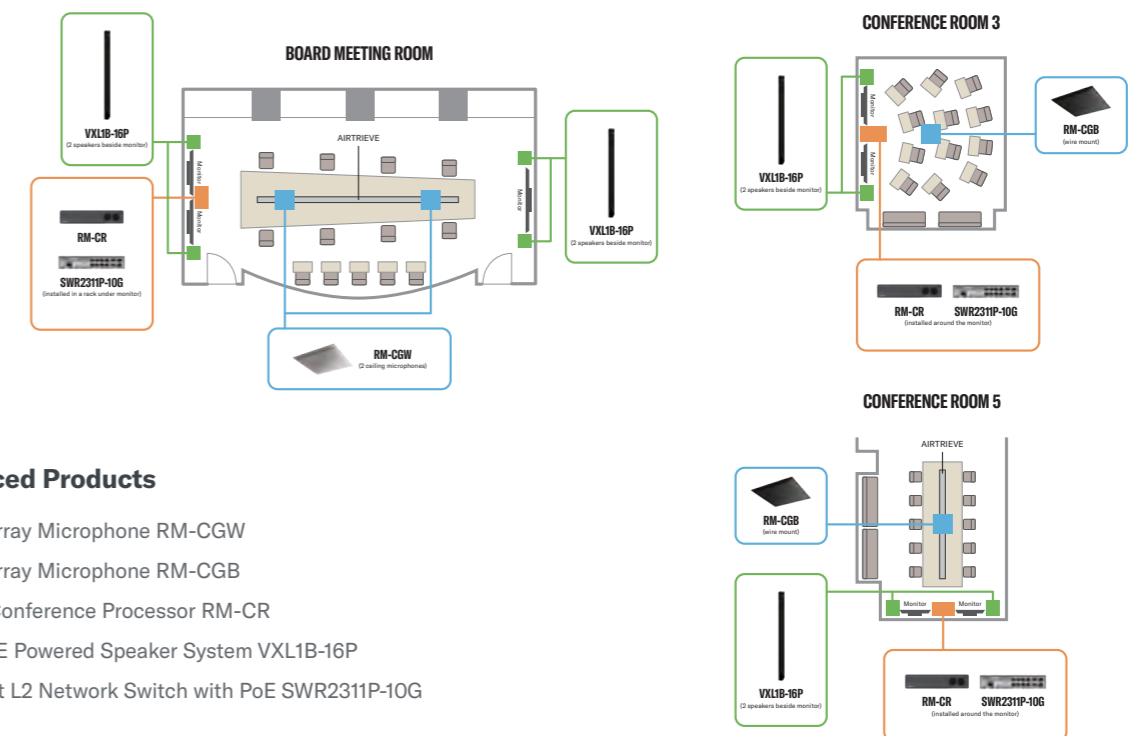

#### Introduced Products

- Ceiling Array Microphone RM-CGW
- Ceiling Array Microphone RM-CGB
- Remote Conference Processor RM-CR
- Dante PoE Powered Speaker System VXL1B-16P
- Intelligent L2 Network Switch with PoE SWR231P-10G





YAMAHA CORPORATION

© 2022 Yamaha Corporation. All rights reserved.  
Product features and specifications are subject to change without notice by Yamaha.  
All other product and company names and logos that appear in this leaflet are trademarks or  
registered trademarks of their respective owners.

BR-ADECIA-SOLUTION-20220706-EN